

Rotary encoder

HE40B/50B

INSTRUCTION MANUAL

Thank you for purchasing HANYOUNG product.
Please check whether the product is the exactly same as you ordered.
Before using the product, please read this instruction manual carefully.
Please keep this manual where you can view at any time

HANYOUNG NUX



HANYOUNGNUX CO.,LTD

HEAD OFFICE 1381-3, Juan-Dong, Nam-Gu Incheon, Korea, TEL:(82-32)876-4697 FAX:(82-32)876-4696 http://www.hynux.net

Safety information

	DANGER DANGER indicates an imminently hazardous situation which, if not avoided, will result in death or serious injury
	WARNING WARNING indicates a potentially hazardous situation which, if not avoided, could result in death or serious injury
	CAUTION CAUTION indicates a potentially hazardous situation which, if not avoided, may result in minor or moderate injury

Warning

- Since this product is not designed as a safely used device the user must install double safety equipment when this product is used for equipment with possible fatal accident or large property damage.

Caution

- Please check for correct model type and specification.
- Please check for any damage or abnormality that may occurred during shipment.
- Rotary encoder is composed of very precision parts so impacting strong shock to the product may damage the function therefore, please handle with care.
- The shield wire of rotary encoder is not connected to the CASE
- If the device is touched or contacted by water then short-circuit and fire may occur so please inspect the device with care
- We recommend the continuous inspection and repair in order to use it safely for a long period of time.
- Not following this instruction manual may result in personal injury and property damage.

■ About Mega Test

- Although it has an internal voltage 800 V d.c between the CASE and electric circuit, internal electric circuit may get damaged or destroyed if users use wrong method when applying the voltage. Therefore, please do not perform the mega test.

■ About Installation

- When installing, do not apply strong force or twist the rotational axis of encoder.
- The life expectancy of rotary encoder varies depending on the using condition or environment so please be cautious
- Do not disassemble, manufacture, upgrade and repair the product by yourself.
- Please turn OFF the product and disassemble the product. Not doing so will break down the product and cause malfunction to occur.
- Rotary encoder is composed of very precision parts so impacting strong shock to the product may damage the function therefore, please handle with care.
- When installing the rotational axis of rotary to the device, please use the Coupling and when installing the Coupling to axis, do not apply strong force.
- When mounting the product, as the eccentricity and angle deviation become larger, the force applied to the shaft will become large too and result may damage the product or shorten the life expectancy.

■ About Environment.

- Please avoid using this product at following environment. Doing so may break down the product or cause malfunction to occur.
- Place where the internal parts or structure become damaged by the strong vibration and shock
- Place near to the machine which generates the strong electromagnetism or electrical noise
- Place that does not fall into the given specification especially for ambient temperature and humidity.

■ About wiring

- Please separate the input signal wire and output signal wire from each other but when separating them from each other is impossible, please use the shield wire for input wire.
- When there are too much noises generating from the power, we recommend using the insulation Trans and noise filter.
- Please check the polarity of terminal before wiring.
- Please make the wiring length as short as possible
- Wiring the rotary encoder wire and power wire to each other may cause malfunction to occur so please be cautious.
- False wiring of rotary encoder may break down the internal circuit so please be cautious
- If type for applying power is SMPS, surge may occur so please connect noise filter (surge observer) to the power terminal and doing so will solve the problem that corresponds to the surge. Also, in order to minimize the effect causing by noise and etc, please make the wiring as short as possible.
- When extending or drawing out the cable, please use the Twist Pair wire. Shield wire must be connected to the F,G terminal!

■ About the vibration

- If strong vibration or shock is carried out through the rotary encoder, incorrect pulse may be generated and this may end up as malfunction of system so please be cautious about the installation place, mounting place and etc.
- As there are much of pulse generation per 1 rotation, the slit gap of rotational slit gets narrower so it may be influenced by vibration easily and the vibration applied during spinning or when it is stopped, it will be carried through out this device so may generate the wrong pulse so please be cautious.
- When inserting the coupling to Shaft, do not apply shock by using the hammer and etc

■ About the Noise

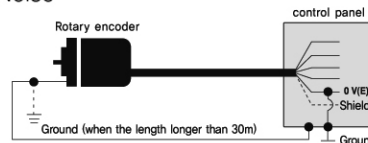

Distance from the control panel	Connection method of rotary encoder
More than 30m	For the case of rotary encoder, please connect it to the controlling case with wire type 3 - 5.5 mm ² . For the 0 V (E) terminal, please connect it to the controlling case with the same type of wire and ground it one more time.
Less than 30m	Refer to the information on the above and ground the rotary encoder.

* Not following the information on the above when handling the product may damage the product so please follow it at all times.

Suffix code

Model	Code	Information
HE	<input type="checkbox"/> - <input type="checkbox"/> <input type="checkbox"/> <input type="checkbox"/> <input type="checkbox"/> <input type="checkbox"/> <input type="checkbox"/>	rotary encoder. Incremental
Dimension	40B 6	Shaft Outer diameter : Ø 40 mm Axis : Ø 6 mm
	8	
	50B 8	Outer diameter : Ø 50 mm Axis : Ø 8 mm
Number of pulse	*	Refer to the pulse code chart(resolving power)
Output signal	2	A, B phase output
	3	A, B, Z phase output
	3C	A, B, Z̄ phase output
	4	A, Ā, B, B̄ phase output
	6	A, Ā, B, B̄, Z, Z̄ phase output
Output circuit	N	12 NPN voltage output (5 - 12 V d.c)
		24 NPN voltage output (12 - 24 V d.c)
	O	12 NPN open collector output (5 - 12 V d.c)
		24 NPN open collector output (12 - 24 V d.c)
	T	12 Totempole output (5 - 12 V d.c)
		24 Totempole output (12 - 24 V d.c)
	L	5 Line Driver output (5 V d.c)
		12 Line Driver output (12 V d.c)
		24 Line Driver output (24 V d.c)

Model	Number of pulse per 1 revolution
HE40B	*1, *2, *5, 10, *12, 15, 20, 25, 30, 40, 45, 50, 60, 75, 100, 120, 125, 150, 192, 200, 240, 250, 256
HE50B	300, 360, 400, 500, 512, 600, 800, 1000, 1024, 1200, 1500, 1800, 2000, 2048, 2500 (385)

* A and B phase only can be generated with 'r' mark (Line drive output : A, Ā, B, B̄ phase)
* Pulses other than pulses in the chart are order made product

Specification

Mode	HE00B	HE00B	HE00B	HE00B
	-□-□-□-□-□-□	-□-□-□-□-□-□	-□-□-□-□-□-□	-□-□-□-□-□-□
Output type	NPN Voltage output	NPN Open collector output	Totem Pole output	Line Drive output
Output signal	A, B, Z phase			A _B Z _A B _Z phase
Phase difference on Output	Phase difference between A, B phase : T/4 ± T/8(Cycle of A phase = T)			
Max Response Frequency	300 kHz			
Power voltage	5 - 12 V d.c / 12 - 24 V d.c ± 5 %			5/12/24 V d.c ± 5 %
Current Consumption	60 mA max. (No-load)			
Connection method	Cable extended type			
Electrical Specification	Control output	Load voltage : 30 V max. Load Current : 30 mA max. Residual Voltage : 0.4 V max.	For Low Load Current : 30 mA max. Remaining Voltage : 0.4 V max.	For Low Load Current : 20 mA max. Remaining Voltage : 0.4 V max.
			For High Load Current : 10 mA max. Remaining Voltage : 2.5 V min.	For High Load Current : 20 mA max. Remaining Voltage : 2.5 V min.
Response Time	1μs max. (Cable length 1.5 m / sink= 30 mA)	1μs max. (Cable length 1.5 m / sink=10 mA)	1μs max. (Cable length 1.5 m / sink= 30 mA)	1μs max. (Cable length 1.5 m / sink= 30 mA)

Mechanical Specification	Starting Torque	Ø40 : 4×10^{-3} N · m max. Ø50 : 7×10^{-3} N · m max.
	Moment of inertia	Ø40 : 4×10^{-6} kg · m ² max, Ø50 : 7×10^{-6} kg · m ² max
	Permissible Shaft Loading	Ø40 : Radial : Within 30 N, Thrust : Within 20 N Ø50 : Radial : Within 50 N, Thrust : Within 30 N
	Max. Permissible Revolution	5000 r/min
	Insulation Resistance	Over 100 M Ω (Base on 500 V d.c mega between terminal and case)
Dielectric strength	800 V a.c (Between terminal and case at 60 Hz for 1 minute)	
Vibration Resistance	10 - 55Hz (Cycle for 1 minute), Double amplitude width: 1.5 mm, Each X · Y · Z direction for 2 hours	
Shock Resistance	Ø40 : 490 % Max., Ø50 : 735 % Max.	
Ambient Temperature	-10 ~ 70 °C(Without condensation),Storage Temperatur : -25 ~ 85 °C	
Ambient Humidity	35 ~ 85 % R.H.	
Protection	Protection IP 50 (IEC Standard)	
Wire Specification	5 P, Ø 5.0 mm, Length : 1.5 m, Shield cable(Option : 2 m, 8 m, 10 m) (Line Driver Type : 8P, Ø 5.0 mm, Length : 1.5 m, Shield cable)	
Weight	Ø 40 : 170 g, Ø 50 : 200 g	
Accessory	Ø 40 : Ø 6.0 or Ø 8.0 mm Coupling, Ø 50 : Ø 8.0 mm Coupling, Bracket	

Dimension

[unit : mm]

■ Ø 40 Axis

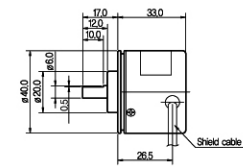
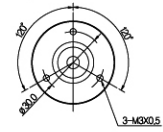

■ Ø 50 Axis

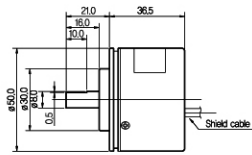
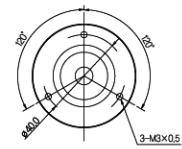

■ Ø 50 Axis (Bracket)

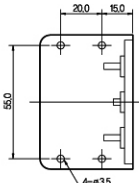
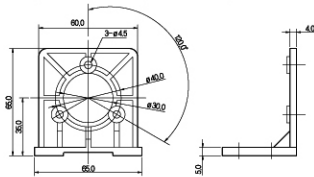

■ Mode # : RC-06 / RC-08 (Coupling)

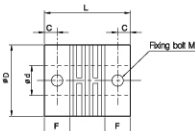
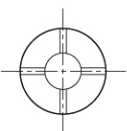

	C	D	d	F	L	M
Ø40	3.5	19	6 ^{+0.05}	7.2	25	M4×5
Ø40, Ø50	3.5	19	8 ^{+0.05}	6.0	23.2	M3×5

※ Please be careful when coupling with revolving shafts that if there are larger coupling errors (parallel misalignment, angular misalignment), the lifetime of the encoder and coupling could be shortened.

Wiring diagram

■ Ø40 Axis

- Voltage output, Totem Pole output, Open collector output
- Line Driver output

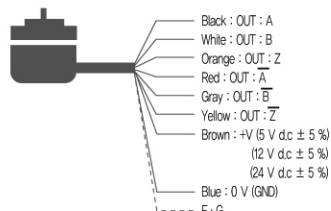
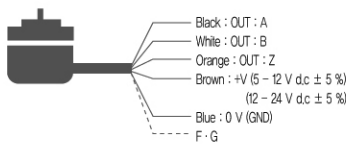

■ Ø50 Axis

- Voltage output, Totem Pole output, Open collector output
- Line Driver output

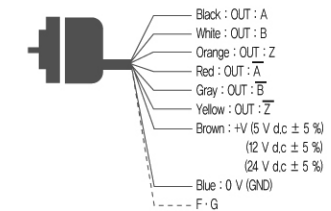
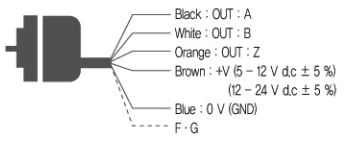

※ Please insulate unused lines

※ Metal case of encoder and Shield line must be ground connection.

Control output circuit diagram

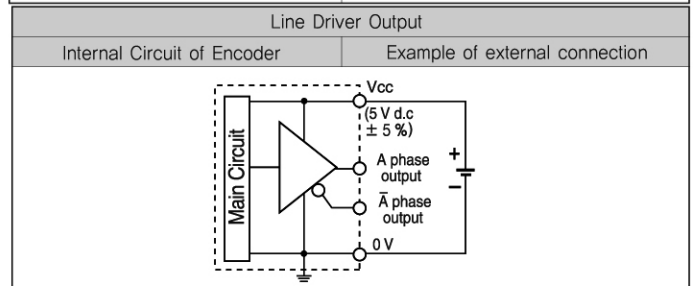
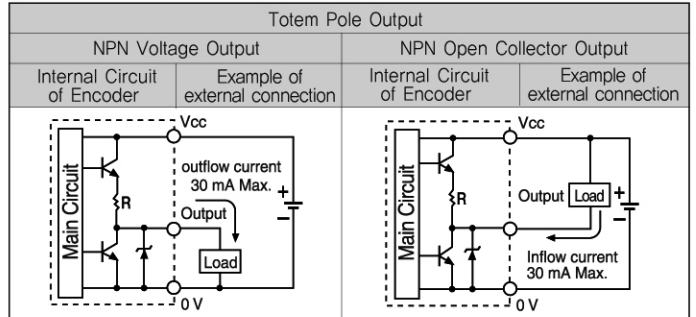
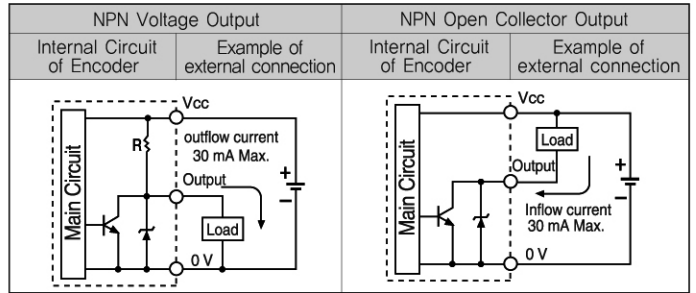

※ The output circuit of A, B, Z phase (Line drive output A, A-bar, B, B-bar, Z, Z-bar phase) is same.

Wiring diagram

■ NPN Voltage output, NPN Open Collector Output, Totem Pole output

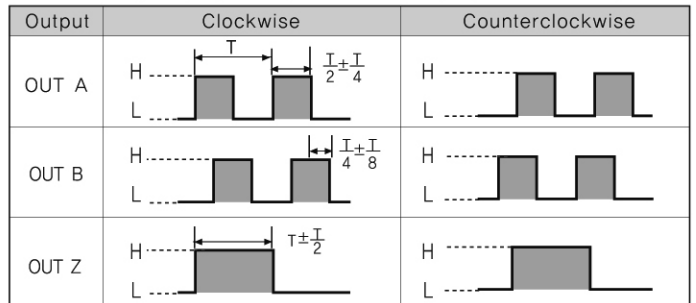

■ Line Driver Output

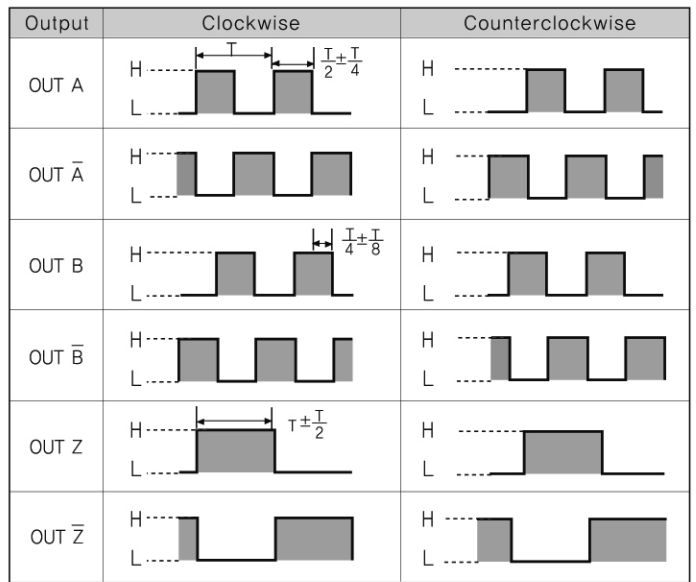

Clockwise (CW): When you are looking at the shaft of the product, it is turning in a clockwise direction.
Counterclockwise (CCW): When you are looking at the shaft of the product, it is turning in a counterclockwise.